

Internally-fed Rotary Drum Filter

Introduction

The internally fed rotary drum filter is an internally-fed screening device with the flow being fed and distributed inside a screening cylinder. It is widely used to separate settleable solids from liquid in the municipal and industrial wastewater treatment plants.

Advantages

- ◆ Well-distributed water increase capacity.
- ◆ Simple structure, stable running, easy maintenance.
- ◆ Chain transmission ensures efficiency.
- ◆ Back-flushing prevents filter clogging.
- ◆ Spill-proof plates on sides avoid splashing water.



Working Principle

The rotary drum filter is mechanical filtration equipment, including a transmission device, overflow weir water distributor, rinse water device and other significant components. The filter drum is made of stainless steel wedge wire screen. The working principle is that the treated water enters the overflow weir distributor from the pipe mouth. After a short period of steady flow, it evenly overflows from the water outlet and distributes the filter drum that rotates in the opposite direction. The water flow will generate a relative shearing motion with the inner wall of the filter drum, in which the solid is retained and separated, and tumbles by following the spiral guide plate in the filter drum, and discharges from the other end of the filter drum, and the wastewater filtered out from the filter drum flows out from the side sink under the flow guiding of protection cover from the right direction. The outside of the filter drum is equipped with a flushing water pipe and is sprayed with pressure water (3Kg/m^2) in a fan-shaped manner to flush and dredge the filter mesh to ensure that the filter mesh always keeps good filtering capability.

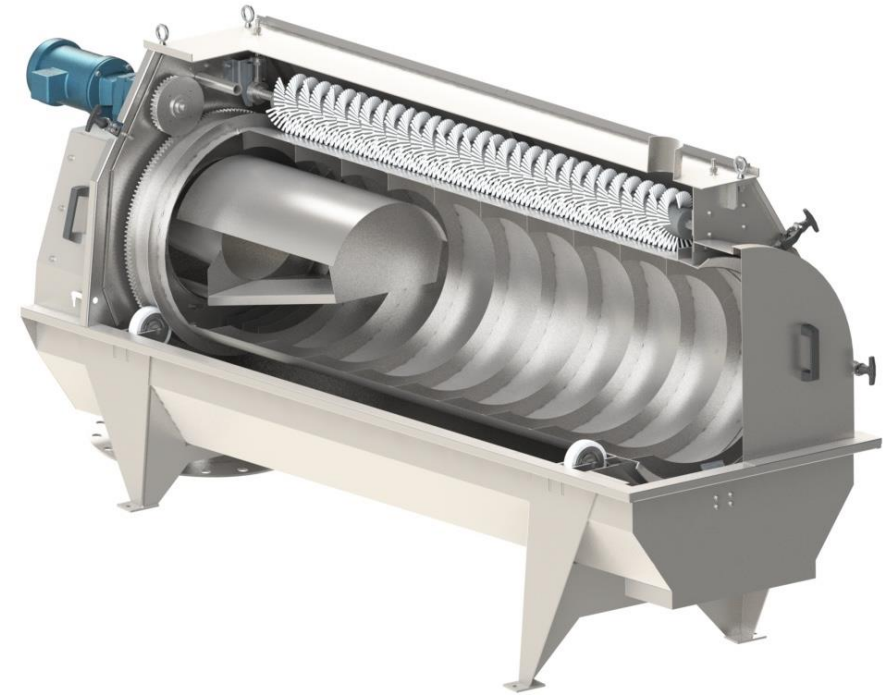

Model

Model	Drum dia (mm)	Slot size (mm)	Removal rate		Size (mm)
			Particle > 0.75mm	Particle > 0.37mm	
JXN-600	600	0.2-2	95%	55%	2450x1000x960
JXN-800	800				3000x1200x1200
JXN-1000	1000				3400x1350x1250
JXN-1200	1200				3500x1850x1450
JXN-1500	1500				3650x1800x1880
JXN-1800	1800				4800x2200x2300
JXN-2000	2000				5500x2400x2500
JXN-2500	2500				7000x2800x3200

*Above parameters only for reference, customized available for detailed requirements

Schematic Diagram

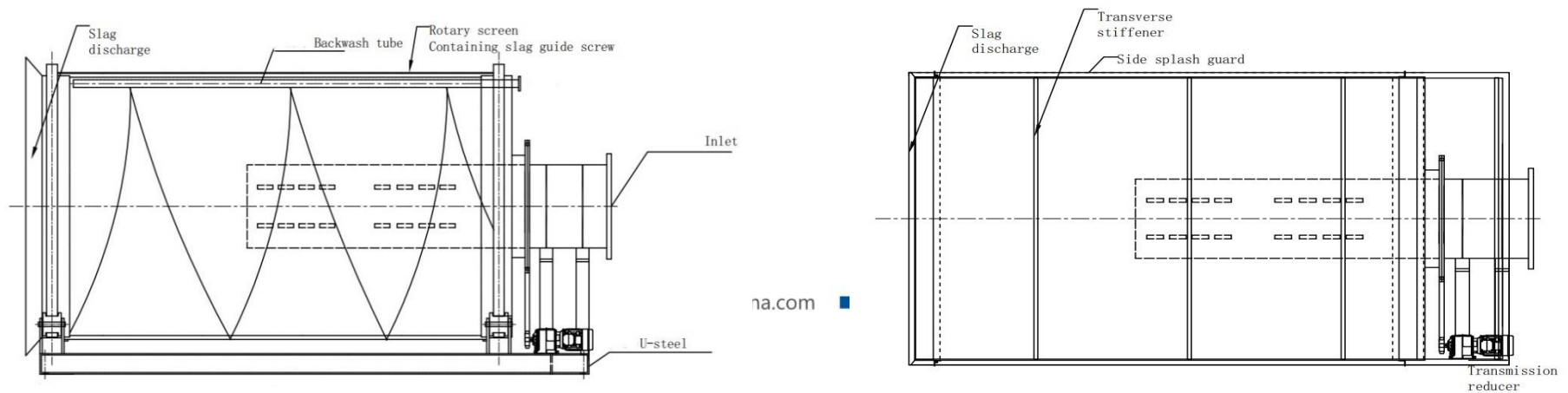

Externally-fed Rotary Drum Filter

Introduction

The Externally Fed Drum Screen is designed for small and medium-sized wastewater treatment plants. It aims to screen the floating solid substances in the water and is widely used in wastewater pretreatment and industrial screening. 30% to 60% of the organic and inorganic floating solid substances will be removed after filtering, significantly reducing the working load of the following process.

Working Principle

As speed regulating motor through a speed reducer drive reseau cylinder, sewage enters the tank through the inlet valve. It rises above the filtering waterline through the buffer box clapboard. The purified water enters into the bottom of the tube through the grid mesh slot and flows out. With this procedure, the grid mesh also has been cleaned at the same time. And during this time, the impurities and organic matters whose size is greater than the slot of the grid mesh is blocked and transferred into the other side of the grid mesh. Finally, the blocked impurities and organic matters are discharged by the unloader into the slag hopper.



Advantages

1. Material: stainless steel, corrosion resistance, compact structure and easy installation;
2. With the inverted trapezoidal section, the grid makes the slag not easy to jams mesh filters;
3. Adopted control motor, the externally fed rotary drum filter can maintain the best working condition according to the water flow;
4. Special flusher device can brush away a small amount of impurity on the surface of the grid mesh;
5. Compact structure, the smallest amount of space when the same amount of processing;
6. The drum surface is made of a molded grid and has excellent hydraulic characteristics.

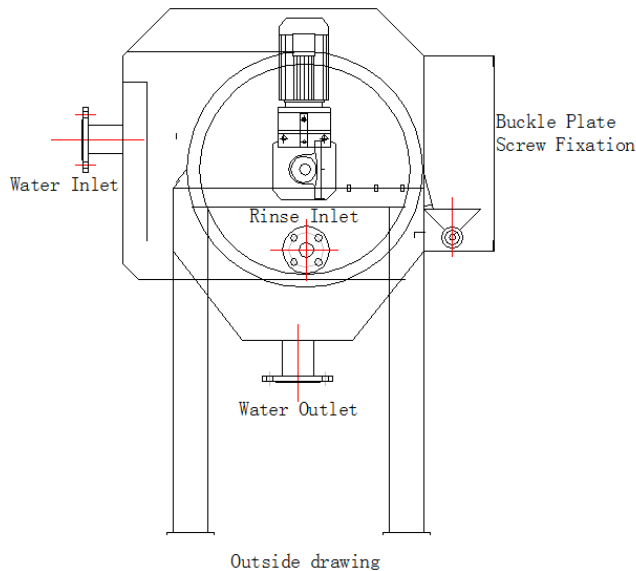

Model	QA-600	Rotating speed (r/min)	Power (Kw)	Backwash water	
				Flow rate (m ³ /h)	Pressure (Mpa)
JXLW-600	600*1000	4-20r/min	0.75	2.5-3	≥0.4
JXLW -800	800*1200		1.1	2.5-3	≥0.4
JXLW 1000	1000*1400		1.5	3.5-4	≥0.4
JXLW -1200A	1200*1500		1.5	3.5-4	≥0.4
JXLW -1200B	1200*2000		2.2	4.5-5	≥0.4
JXLW-1500	1500*2000		3	4.5-5	≥0.4

Channel Rotary Drum Screen

Introduction

Channel Drum Screens are widely used in wastewater treatment of municipal wastewater, industrial wastewater, food processing, paper-making, etc. This equipment can remove the scum, short fiber, suspended solids from the water intake and then discharge them after pressing.

Operation

Solids within the incoming flow will enter into the drum screen and progressively collect onto the screen mesh and cause it to gradually blind. The upstream water level will rise and at a predetermined level, the drum screen and screw conveyor will activate and rotate, immersing a clean section of the screen into the effluent. During rotation, the solids or screenings will become inverted and then fall into the screw conveyor. Spray nozzles and a roller brush fixed to the drum screen's periphery will clean away any residual solids from the mesh surface. The screenings are conveyed, compacted, and dewatered. Depending upon the solid properties, a volume reduction of around 40% DS or greater can be achieved before disposing of the screenings into a skip or holding vessel. A jet wash facility in the compaction zone will breakdown and remove fecal and other semi-solid or soluble mater and return it to the inlet flow. Additional jets can be installed in the transport zone to meet higher specifications of organic solids removal. Fecal matter washing efficiencies greater than 90% and screenings weight reduction of 50% can be achieved. The compactor and wash system can be omitted to suit requirements such as CSO applications where the screenings are returned to the downstream sewer.



Advantages

1. High quality and reliability at low cost;
2. Reduced disposal costs because of the screenings press;
3. High solids capture;
4. Easily installed onto an existing or new treatment works;
5. Non-clogging even with fibrous materials;
6. Protection of downstream plant and drains;
7. Improved Health & Safety with optional continuous bagging;
8. Enclosed drum screen to prevent wastewater splash.

Application

- ◆ Process liquor or fluid screening
- ◆ Municipal wastewater treatment works
- ◆ Industrial effluent discharges
- ◆ MBR Membrane pre-screening
- ◆ Commercial outlet discharges
- ◆ Storm flows
- ◆ Sea outfall discharges



Model Selection

Model		JXCR-600	JXCR-800	JXCR-1000	JXCR-1200	JXCR-1400	JXCR-1600	JXCR-1800	JXCR-2000	
Drum dia.		600	800	1000	1200	1400	1600	1800	2000	
Standard mesh L		650	850	1000	1200	1400	1500	1650	1850	
O.D. of conveying pipe		159	219	219	273	273	325	325	325	
Highest water level H3		400	520	670	820	950	1100	1250	1350	
Standard installation angle		35°								
Average channel depth H2		600-800	700-1000	900-1200	1100-1400	1200-1600	1400-1800	1600-2000	1800-2100	
Average slag discharging depth H1		1000mm								
Min. Installation length A		3000	3300	3600	4000	4300	4700	5000	5300	
Max. Flowrate (m ³ /h)	slot	0.5	80	135	235	315	450	585	745	920
		1	125	215	370	505	720	950	1205	1495
		2	1990	330	555	765	1095	1440	1830	2260
		3	230	400	680	935	1340	1760	2235	2755
		4	235	430	720	1010	1440	2050	2700	3340
		5	250	465	795	1105	1575	2200	2935	3600

Mechanical Bar Screen



Introduction

The mechanical bar screen is specifically designed to quickly and efficiently remove large slugs of debris from the channel. This heavy-duty screen uses a reciprocating rake to clean the automatic bar screen and pull out debris in headworks and pump stations. This wastewater bar screen's robust design makes it ideal for dealing with massive storm flows that can overwhelm a lesser mechanical bar screen.

Main Structure

Drum, driving mechanism (motor reducer), unloading device, backwashing pipe, seal assembly, inspection door, frame, etc.

Advantages

1. High flow rate with small heat loss and a high interception rate;
2. With a compact structure, it integrates filtration and slugging into one;
3. The unique filter screen design allows the device to effectively remove fibers, hair and other materials in the water;
4. Low energy consumption, low noise and long service life;
5. A fully enclosed structure design with no odor leakage ensures an excellent operating environment.

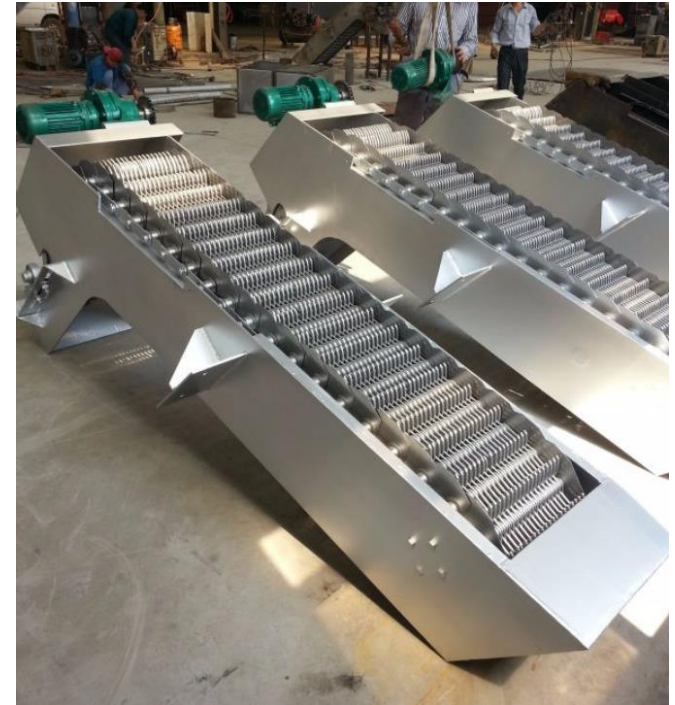

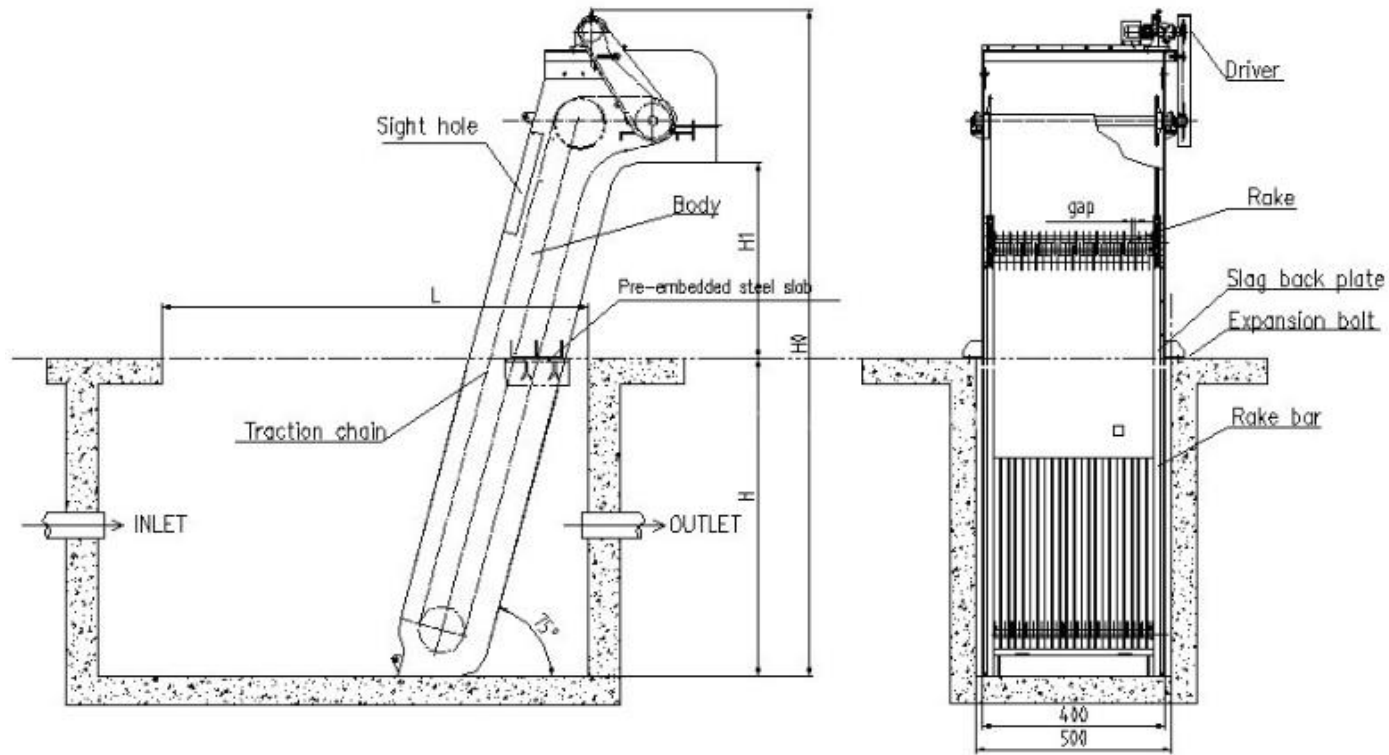

Bar screen

Model Selection

Model	JXGF-300	JXGF-400	JXGF-500	JXGF-600	JXGF-700	JXGF-800	JXGF-900	JXGF-1000	JXGF-1200	JXGF-1250	JXGF-1300
Install angle α											
Motor power (KW)	0.37-0.75		0.55-1.1			0.75-1.5		1.1-2.2		1.5-3	
Screen running speed (m/min)	About 2										
Width of equipment (mm)	300	400	500	600	700	800	900	1000	1200	1250	1300
Total height of equipment (mm)	The depth of channel+ Height of foot to the top of discharge+1350										
Total width of equipment (mm)	650	750	850	950	1050	1150	1250	1350	1550	1600	1850
Width of channel (mm)	400	500	600	700	800	900	1000	1100	1300	1350	1600
Depth of channel (mm)	1000-2000(Customized)										
Length of diversion channel (mm)	1500+Hxctga										
Upper limit temperature of media (°C)	≤ 80 °C										
Height of foot to the top of discharge (mm)	400-1000(Customized)										